

Toggle clamps

Rapid clamping - reliable fastening

Durable and reliable: More reliable, more user-friendly and safer. These clamps are quick to use, reliable and accurate. The use of high quality materials ensures a long working life.

Advantages

- **Extremely tough** : All models will withstand 300,000 clamping cycles without problems
- **Durable** : High-quality bushes - no scratching
- **Extremely robust** : tCorrosion-resistant NITROX coating
- **Easy to use** : The fixed headed nut facilitates spindle adjustment
- **Reliable** : Constant level of force during both opening and closing
- **Ideal where space is restricted** : The slim design allows sufficient space for safe operation
- **Robust by design** : Thanks to use of U-shaped conical clamping arm
- **Safe to use** : No sharp edges prevent risk of anything getting trapped
- **Quick to put into operation** : Can be easily modified thanks to a wide range of accessories
- **Ergonomic design** : Easy to operate whilst wearing work gloves
- **Reflection free finish** : Suitable for use around lasers
- **Risk free use** : With increased space between clamping arm and handle avoids risks of squashing
- **Extremely adaptable** : Rectangular mounting holes allows installation on existing fixing points
- **Efficient clamping and locking** : The integrated design avoids any risks of squashing. Easy to use even whilst wearing gloves.

Locking mechanism – principal of operation



1. Locked in closed position. Redesigned handle ensures safe operation as the smooth contours avoid any risk of anything being trapped.

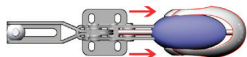

2. Inner locking mechanism with automatic safety catch. The lock is released by pulling the handle.



3. Locked in open position. Releasing the handle engages the locking mechanism.



Horizontal toggle clamp

New

SLHHLOK

With locking mechanism

High quality swivel bush with horizontal foot and adjustable spindle

Constant level of force during both opening and closing

Increased stability thanks to U-shaped clamping arm fitted with automatic locking mechanism

- Materials :

Nitro carburised steel with blackened finish

Polyamide handle

Locking mechanism TPE

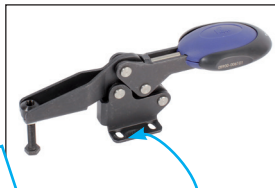

NEW!

Horizontal base

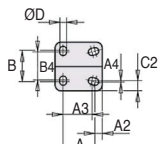
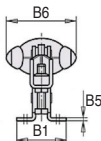
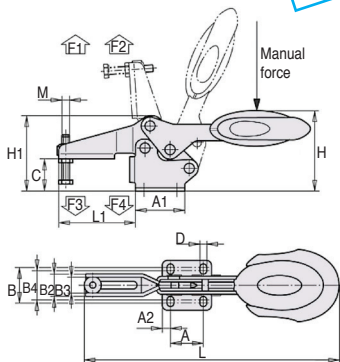

Hole positions

DISCOUNTS

Qty	1+	6+	15+	20+
Disc.	List	-5%	-10%	On request

Part number	Opening angle		Manual force N	Holding force		Clamping force		H	H1	L	L1
	Holding arm	Handle		F1 (N)	F2 (N)	F3 (N)	F4 (N)				
SLHH-6/LOK	87°	68°	160	1350	1900	720	1200	63,3	59,5	193,3	60,5
SLHH-8/LOK	86°	66°	200	2000	2800	830	1400	73,9	70	230,3	74,9
SLHH-10/LOK	90°	71°	250	2200	4500	1200	2800	94,8	87,9	286	103,9
SLHH-12/LOK	88°	68°	280	2400	5500	1000	2800	104,9	101,6	321,3	122

Part number	M	A	A1	A2	A3	A4	B	B1	B2	B3	B4	B5	B6	C	C2	ØD	Price each
																	1 to 5
SLHH-6/LOK	M6x35	26	39	6,5	-	-	28	39	17,5	12,4	24,6	53,4	53,4	25,5	-	5,5	51,38 €
SLHH-8/LOK	M8x45	26	44	9	-	-	31	45	21	15,7	26,1	51,1	51,1	32,2	-	6,2	52,31 €
SLHH-10/LOK	M10x55	41,5	59	9	-	-	43	59	26	18,7	39	56,5	56,5	40	-	8,8	70,14 €
SLHH-12/LOK	M12x70	44	65	10	40	1	42	67	28	20,9	40	56,5	56,5	52,3	13,5	8,5	73,16 €

Altri prodotti...



GB-RA

Ingranaggio dritto
ottone, Ottone
CuZn39Pb3



WINGbrEcrou

Dado ad alette per
serraggio manuale
DIN315, Ottone DIN
315



DER63

Motore inox AC
asincrono 0,18kW,
0.18kW



SVT20

Martinetto a vite - Vite
traslante, Vite
traslante



CHB

Feet, For CHB gearbox



STU

Boccola a sfere
lineare e rotativa,
Acciaio

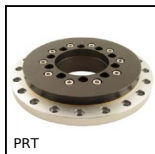

PRT

Corona girevole
Iglidur®, Iglidur®,
alluminio e inox



MHX

Manicotto esagonale
maschiato, Esagonale
- acciaio



PSG25S

Ingranaggio dritto di
precisione, Inox 303



CHM75

Riduttore a ruota e
vite senza fine, fino a
298 Nm



SCA

Serracavo, Acciaio



M0

Coppia ruota e vite
senza fine, Plastica
lavorata (delrin)

Prodotti correlati



SLH-M

Dado per bloccaggio a
leva, Dado con
estremità sferica



SLH

Attrezzo di bloccaggio
a leva orizzontale, A
leva orizzontale -
acci...