

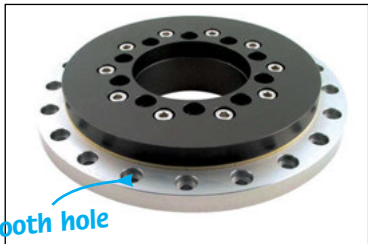

Advantages

- No maintenance required
- Low coefficient of friction
- Cost effective
- Robust
- Rigid
- Easily installed
- Wear resistant
- Materials:
 Sliding mechanism: iglidur®
 Ring: hard anodised aluminium
 Screws: stainless steel



Tipping dependent on overturning torque

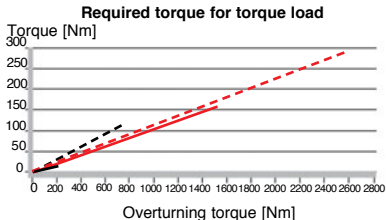
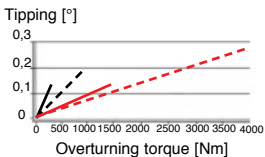

Required torque for eccentric loads

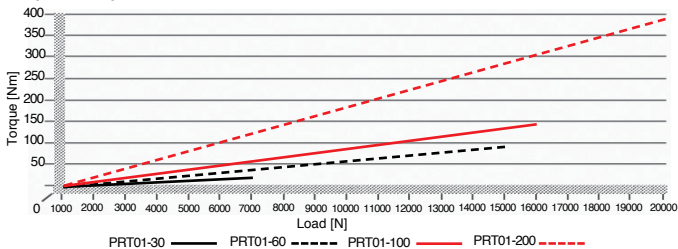

Part number	Weight (kg)	Axial load rating, static (N)	Axial load rating, dynamic (N)	Axial load rating, dynamic (N)	Radial load rating, dynamic (N)	Rotary speed limit, dry (1/min)	Rigidity, axial (N/μm)	Rigidity, radial (N/μm)	Max. permitted Overturning torque (Nm)	Dimensions		
										R1	R2	B
PRT01-30	0,4	27 000	7 000	5 000	1 500	250	-	-	200	41	29,0	4,5
PRT01-60	1,1	50 000	15 000	10 000	3 000	200	300	65	800	65	51,5	4,5
PRT01-100	1,3	55 000	16 000	16 000	5 000	150	400	65	1 500	80	69,0	5,5
PRT01-200	3,2	100 000	30 000	35 000	10 000	80	500	65	3 800	137	123,0	7,0

Dimensions in mm

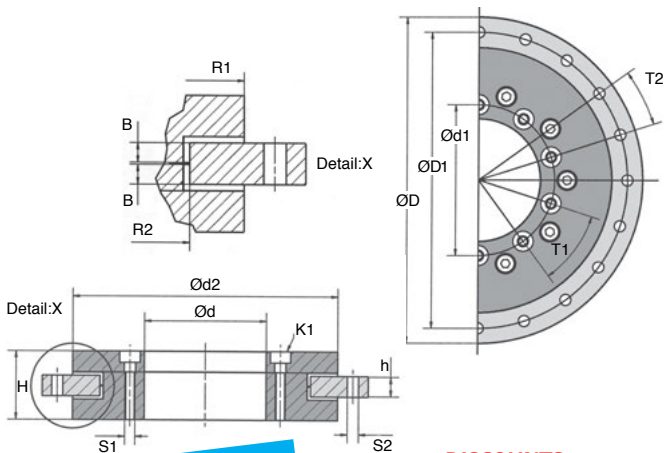
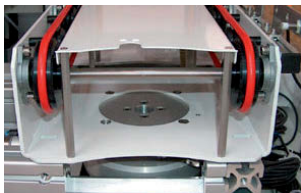
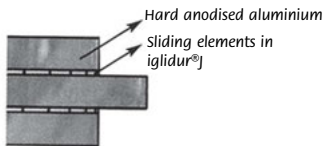

New sizes

DISCOUNTS

Qty	1+	5+	10+
Disc.	List	-5%	On request

Part number	ØD	ØD1	Ød1	Ød	Ød2	H	h	T1	T2	S1	S2	K1 for screw	Price each
													1 to 4
PRT01-20	80	70	31	20	60	24	8	3 x 120°	6 x 60°	M4	4,5	DIN 7984 M4	164,37 €
PRT01-30	100	91	42,5	30	82	29	10	8 x 45°	8 x 45,0°	M4	4,5	DIN 7984 M4	182,06 €
PRT01-50	150	135	65	50	120	33	10	8 x 45°	16 x 22,5°	M6	6,6	ISO 4762 M6	251,59 €
PRT01-60	160	145	74,0	60	130	33	10	10 x 36°	20 x 18,0°	M5	5,5	DIN 912 M5	274,50 €
PRT01-100	185	170	112,0	100	160	34	12	12 x 30°	16 x 22,5°	M5	5,5	DIN 912 M5	506,51 €
PRT01-150	250	235	165	150	220	35	12	12 x 30°	16 x 22,5°	M6	5,5	ISO 4762 M5	701,18 €
PRT01-200	300	285	215,0	200	274	38	15	12 x 30°	16 x 22,5°	M6	7,0	DIN 912 M6	903,83 €

Dimensions in mm

Altri prodotti...



GE1006

Chiusura a leva adattabile, Per aggancio in gola



GP

Chiusura a leva molla a trazione compensata, Standard

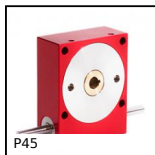

P45

Riduttore a ruota e vite senza fine, fino a 40 Nm



PLB

Distanziatore cilindrico, Ottone



KITbuh

Kit di motorizzazione 24V, Planetario



DOG258

Motoriduttore DC 12V e 24V DC, da 12 a 15 Nm

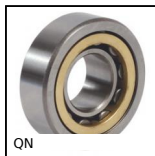

QN

Cuscinetto a singola corona di rulli cilindrici, Anello esterno libero

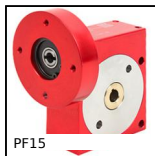

PF15

Riduttore a ruota e vite senza fine, fino a 3,75 Nm



DGSA

Testa a snodo maschio, Acciaio / acciaio - Serie



CHAuss

Cerniera ad avvitare, 270°



VTSM

Ball head screws Hygienic Design®, Inox



AKD

Giunto a soffietto Gerwah®, da 22 a 600Nm

Prodotti correlati

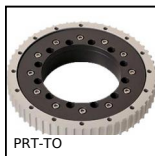

PRT-TO

Corona girevole Iglidur®, Con dentatura esterna- Iglidur®, allumini...