

Linear ball slide **Eco range**



GCL5 GCL7

Dynamic load from 516N to 1631N

- Linear slide for normal loads
- Recirculating ball type linear slide
- Material:
Stainless steel
- Note: part numbers of rails and slide units are separate: remember to order both



NEW!

Self-lubricated slide + Rail

Applications

- Inspection equipment, automation, cartesian coordinated robot, medical equipment

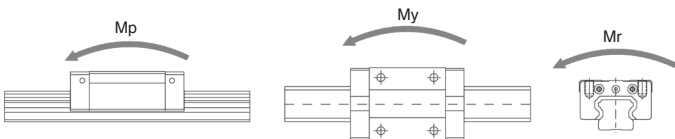
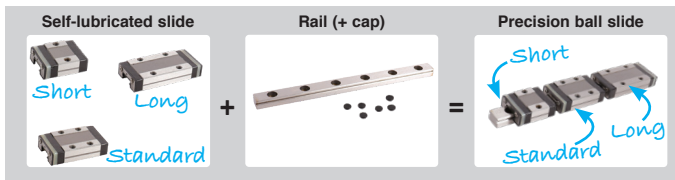

Part number	Type	Basic load rating		Static allowance moment (kN-m)				Mass		
		C (N)	Co (N)	Mp	My	Mr	Slide (kg)	Rail (kg/m)		
GCL5C-1LF	Short	516	757	1,3	7,1	1,3	7,1	2,01	3,1	0,139
GCL5-1LF	Standard	631	1009	2,2	11,6	2,2	11,6	2,67	4,0	0,139
GCL7C-1LF	Short	901	1136	1,9	11,8	1,9	11,8	4,14	6,4	0,253
GCL7-1LF	Standard	1197	1703	4,2	23,1	4,2	23,1	6,22	9,0	0,253
GCL7G-1LF	Long	1631	2650	10,1	50,0	10,1	50,0	9,67	12,6	0,253

All dimensions in mm

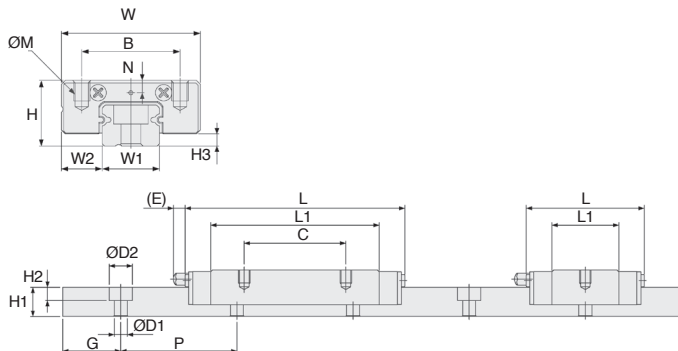

DISCOUNTS

Qty	1+	4+	8+
Disc.	List	-6%	On request

Self-lubricated slide units

Part number	Type	H	W	L	B	C	ØM	L1	N	E	Grease nipple	H3	Price Each 1 to 3
GCL5C-1LF	Short	6	12	17,0	8	-	M2x1,5	9,4	1,2	-	-	1	50,75 €
GCL5-1LF	Standard	6	12	20,0	8	-	M2x1,5	12,4	1,2	-	-	1	51,88 €
GCL7C-1LF	Short	8	17	19,8	12	-	M2x2,5	9,6	1,5	-	-	1,5	37,80 €
GCL5-1LF	Standard	8	17	24,3	12	8	M2x2,5	14,1	1,5	-	-	1,5	38,60 €
GCL7G-1LF	Long	8	17	31,8	12	13	M2x2,5	21,6	1,5	-	-	1,5	39,88 €

Rail

Part number	Wide W1	Length L	Height H1	Pitch G	Ø D1	Ø D2	Mass (g)	Price Each 1 to 3	
GCL5-60	5 +0/-0,02	60	3,5	3,7	5	15	2,4 3,6 0,8	8	29,83 €
GCL5-90	5 +0/-0,02	90	3,5	3,7	5	15	2,4 3,6 0,8	13	44,73 €
GCL5-120	5 +0/-0,02	120	3,5	3,7	5	15	2,4 3,6 0,8	17	59,65 €
GCL5-150	5 +0/-0,02	150	3,5	3,7	5	15	2,4 3,6 0,8	21	74,55 €
GCL5-180	5 +0/-0,02	180	3,5	3,7	5	15	2,4 3,6 0,8	25	89,48 €
GCL5-210	5 +0/-0,02	210	3,5	3,7	5	15	2,4 3,6 0,8	29	104,38 €
GCL7-60	7 +0/-0,02	60	5	5	5	15	2,4 4,2 2,3	8	10,00 €
GCL7-90	7 +0/-0,02	90	5	5	5	15	2,4 4,2 2,3	13	14,98 €
GCL7-120	7 +0/-0,02	120	5	5	5	15	2,4 4,2 2,3	17	19,98 €
GCL7-150	7 +0/-0,02	150	5	5	5	15	2,4 4,2 2,3	21	24,98 €
GCL7-180	7 +0/-0,02	180	5	5	5	15	2,4 4,2 2,3	25	29,98 €
GCL7-240	7 +0/-0,02	240	5	5	5	15	2,4 4,2 2,3	33	39,95 €
GCL7-300	7 +0/-0,02	300	5	5	5	15	2,4 4,2 2,3	42	49,95 €

All dimensions in mm

Linear ball slide **Eco range**



GCL9 GCL12

Dynamic load from 1180N to 4246N

- Linear slide for normal loads
- Recirculating ball type linear slide
- Material:
Stainless steel
- Note: part numbers of rails and slide units are separate: remember to order both



Self-lubricated slide + Rail

NEW!

Applications

- Inspection equipment, automation, cartesian coordinated robot, medical equipment

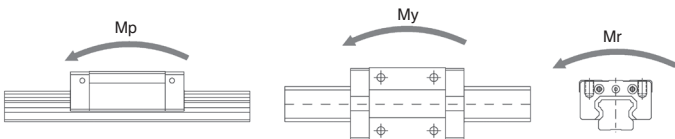
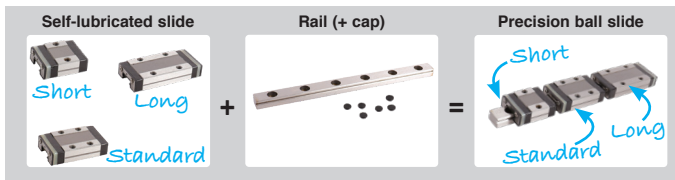

Part number	Type	Basic load rating		Static allowance moment (kN·m)					Mass	
		C (N)	Co (N)	Mp	My	Mr	Slide (kg)	Rail (kg/m)		
GCL9C-1LF	Short	1180	1485	3.1	17.9	3.1	17.9	6.90	9.9	0.391
GCL9-1LF	Standard	1721	2545	9.3	46.6	9.3	46.6	11.84	17.1	0.391
GCL9G-1LF	Long	2375	4030	21.9	102.8	21.9	102.8	18.74	25.2	0.391
GCL12C-1LF	Short	2175	2385	5.4	32.9	5.4	32.9	14.79	19.8	0.679
GCL12-1LF	Standard	3023	3816	14.4	75.8	14.4	75.8	23.66	31.5	0.679
GCL12G-1LF	Long	4246	6200	34.8	169.1	34.8	169.1	38.44	45.9	0.679

All dimensions in mm

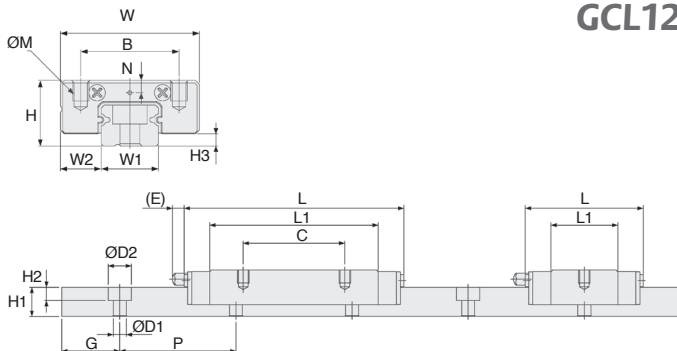

DISCOUNTS

Qty	1+	4+	8+
Disc.	List	-6%	On request

Self-lubricated slide units

Part number	Type	H	W	L	B	C	ØM	L1	N	E	Grease nipple	H3	Price Each 1 to 3
GCL9C-1LF	Short	10	20	22,4	15	-	M3x3	11,8	2,2	-	-	2	38,95 €
GCL9-1LF	Standard	10	20	31,3	15	10	M3x3	20,7	2,2	-	-	2	39,23 €
GCL9G-1LF	Long	10	20	41,4	15	16	M3x3	30,8	2,2	-	-	2	44,75 €
GCL12C-1LF	Short	13	27	26,4	20	-	M3x3,5	12,8	2,7	-	-	3	43,63 €
GCL12-1LF	Standard	13	27	34,9	20	15	M3x3,5	21,3	2,7	-	-	3	43,85 €
GCL12G-1LF	Long	13	27	45,4	20	20	M3x3,5	31,8	2,7	-	-	3	48,25 €

Rail

Part number	Wide W1	Length L	Height H1	W2	H1	G	Pitch P	Ø D1	Ø D2	H2	Mass (g)	Price Each 1 to 3
GCL9-60	9 +0/-0,02	60	5,5	6	7,5	20	3,5	6	3,5	23		9,18 €
GCL9-120	9 +0/-0,02	120	5,5	6	7,5	20	3,5	6	3,5	47		18,35 €
GCL9-160	9 +0/-0,02	160	5,5	6	7,5	20	3,5	6	3,5	63		24,48 €
GCL9-240	9 +0/-0,02	240	5,5	6	7,5	20	3,5	6	3,5	94		36,70 €
GCL9-280	9 +0/-0,02	280	5,5	6	7,5	20	3,5	6	3,5	109		42,80 €
GCL9-480	9 +0/-0,02	480	5,5	6	7,5	20	3,5	6	3,5	188		73,40 €
GCL9-720	9 +0/-0,02	720	5,5	6	7,5	20	3,5	6	3,5	282		110,09 €
GCL9-860	9 +0/-0,02	860	5,5	6	7,5	20	3,5	6	3,5	336		131,50 €
GCL12-50	12 +0/-0,025	50	7,5	8	10	25	3,5	6,5	4,5	20		8,28 €
GCL12-100	12 +0/-0,025	100	7,5	8	10	25	3,5	6,5	4,5	39		16,55 €
GCL12-150	12 +0/-0,025	150	7,5	8	10	25	3,5	6,5	4,5	59		24,80 €
GCL12-200	12 +0/-0,025	200	7,5	8	10	25	3,5	6,5	4,5	78		33,08 €
GCL12-245	12 +0/-0,025	245	7,5	8	10	25	3,5	6,5	4,5	96		45,48 €
GCL12-350	12 +0/-0,025	350	7,5	8	10	25	3,5	6,5	4,5	137		57,88 €
GCL12-400	12 +0/-0,025	400	7,5	8	10	25	3,5	6,5	4,5	156		66,15 €
GCL12-475	12 +0/-0,025	475	7,5	8	10	25	3,5	6,5	4,5	186		78,55 €
GCL12-1000	12 +0/-0,025	1000	7,5	8	10	25	3,5	6,5	4,5	391		165,38 €

All dimensions in mm

Linear ball slide **Eco range**



GCL15 GCL20

Dynamic load from 3418N to 8396N

- Linear slide for normal loads
- Recirculating ball type linear slide
- Material:
Stainless steel
- Note: part numbers of rails and slide units are separate: remember to order both



Self-lubricated slide + Rail

NEW!

Applications

- Inspection equipment, automation, cartesian coordinated robot, medical equipment

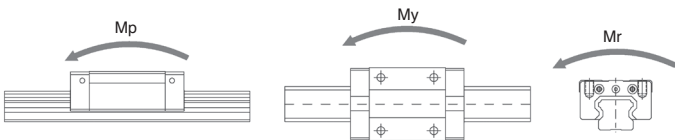
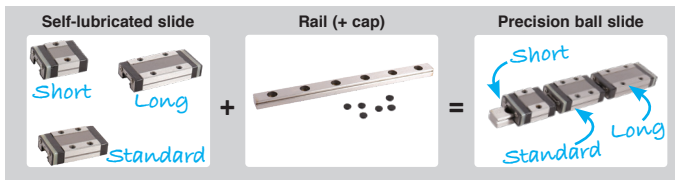

Part number	Type	Basic load rating		Static allowance moment (kN·m)					Mass	
		C (N)	Co (N)	Mp	My	Mr	Slide (kg)	Rail (kg/m)		
GCL15C-1LF	Short	3418	3895	12,2	71,6	12,2	71,6	29,99	37,8	1,071
GCL15-1LF	Standard	4540	5842	28,6	148,7	28,6	148,7	44,99	57,6	1,071
GCL15G-1LF	Long	6492	9737	73,5	351,2	73,5	351,2	74,98	85,5	1,071
GCL20C-1LF	Short	4512	5299	20,7	115,9	20,7	115,9	54,05	80,1	1,572
GCL20-1LF	Standard	6191	8328	50,2	252,7	50,2	252,7	84,94	119,7	1,572
GCL20G-1LF	Long	8396	12870	118,6	554,4	118,6	554,4	131,27	176,4	1,572

All dimensions in mm

GCL15 GCL20

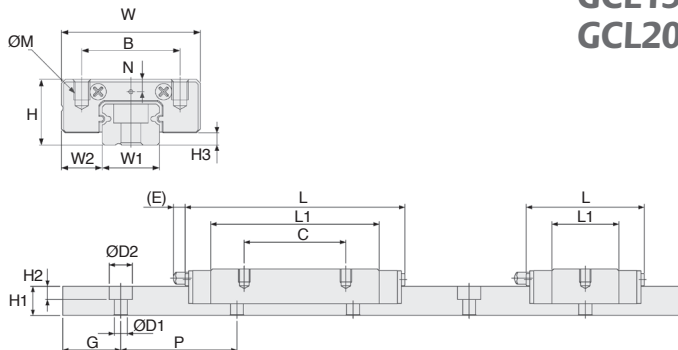

DISCOUNTS

Qty	1+	4+	8+
Disc.	List	-6%	On request

Self-lubricated slide units

Part number	Type	H	W	L	B	C	ØM	L1	N	E	Grease nipple	H3	Price Each 1 to 3
GCL15C-1LF	Short	16	32	34,4	25	-	M3x4	17,7	3,1	3,3	A-M3	4	44,83 €
GCL15-1LF	Standard	16	32	44,4	25	20	M3x4	27,7	3,1	3,3	A-M3	4	62,25 €
GCL15G-1LF	Long	16	32	59,4	25	25	M3x4	42,7	3,1	3,3	A-M3	4	51,78 €
GCL20C-1LF	Short	20	40	39,8	30	-	M4x6	22,2	4,2	3,3	A-M3	5	59,70 €
GCL20-1LF	Standard	20	40	51,8	30	25	M4x6	34,2	4,2	3,3	A-M3	5	62,25 €
GCL20G-1LF	Long	20	40	69,8	30	30	M4x6	52,2	4,2	3,3	A-M3	5	66,18 €

Rail

Part number	Wide W1	Length L	Height H1	Pitch P	Ø D1	Ø D2	H2	Mass (g)	Price Each 1 to 3		
GCL15-80	15 +0/-0,025	80	8,5	10	15	40	3,5	6,5	4,5	86	16,35 €
GCL15-120	15 +0/-0,025	120	8,5	10	15	40	3,5	6,5	4,5	129	24,55 €
GCL15-160	15 +0/-0,025	160	8,5	10	15	40	3,5	6,5	4,5	171	32,73 €
GCL15-260	15 +0/-0,025	260	8,5	10	15	40	3,5	6,5	4,5	278	53,17 €
GCL15-320	15 +0/-0,025	320	8,5	10	15	40	3,5	6,5	4,5	343	65,45 €
GCL15-440	15 +0/-0,025	440	8,5	10	15	40	3,5	6,5	4,5	471	89,98 €
GCL15-480	15 +0/-0,025	480	8,5	10	15	40	3,5	6,5	4,5	514	98,15 €
GCL15-560	15 +0/-0,025	560	8,5	10	15	40	3,5	6,5	4,5	600	114,53 €
GCL15-680	15 +0/-0,025	680	8,5	10	15	40	3,5	6,5	4,5	728	139,05 €
GCL15-960	15 +0/-0,025	960	8,5	10	15	40	3,5	6,5	4,5	1028	196,32 €
GCL15-1000	15 +0/-0,025	1000	8,5	10	15	40	3,5	6,5	4,5	1071	204,50 €
GCL20-120	20 +0/-0,03	120	10	11	20	60	6	9,5	5,5	189	40,68 €
GCL20-180	20 +0/-0,03	180	10	11	20	60	6	9,5	5,5	283	61,00 €
GCL20-240	20 +0/-0,03	240	10	11	20	60	6	9,5	5,5	377	81,33 €
GCL20-360	20 +0/-0,03	360	10	11	20	60	6	9,5	5,5	566	122,00 €
GCL20-480	20 +0/-0,03	480	10	11	20	60	6	9,5	5,5	755	162,68 €
GCL20-660	20 +0/-0,03	660	10	11	20	60	6	9,5	5,5	1038	223,68 €
GCL20-840	20 +0/-0,03	840	10	11	20	60	6	9,5	5,5	1320	284,68 €
GCL20-960	20 +0/-0,03	960	10	11	20	60	6	9,5	5,5	1509	325,33 €
GCL20-1440	20 +0/-0,03	1440	10	11	20	60	6	9,5	5,5	2264	488,02 €

All dimensions in mm

Altri prodotti...



ACLERP
Rulliera, Con guida laterale

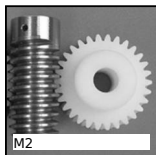

M2
Coppia ruota e vite senza fine, Plastica lavorata (delrin)



SCA
Serracavo, Acciaio



PRF_GAL
Rotella per profilo alluminio, Rotella cava $\varnothing 12$



UTKswr
Guida lineare Utilitrack®, Profilo guida a V

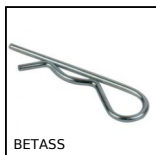

BETASS
Coppiglia beta, Beta



ACL-PLAngle
Elementi di giunzione, Collegamento angolare



PDD
Pressore a molla sensore di rilevamento, Con asta di comando per int...

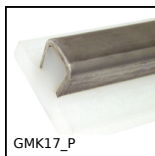

GMK17_P
Guida prodotto laterale piatta, Per



DB
Ingranaggio conico - Acciaio 60C40, 2:1



MEB
Ingranaggio conico in plastica stampata, 1:1



BLHT60
Rinvio angolare a T, da 26 a 70 Nm

Prodotti correlati



GCL
Guida lineare a sfere - Sfere inox, Carello - da 516 N a 8396 N