

Zamak

CLBT CLBTss

- Maniglia a ripresa con asta filettata ed estremità piatta a norma DIN 78

- Materiali:

Fissaggi: acciaio classe 5.8 o Inox 303

Manopola: zamak a norma DIN 1743

- Finitura: acciaio brunito

- Colore: nero

Con asta
filettata

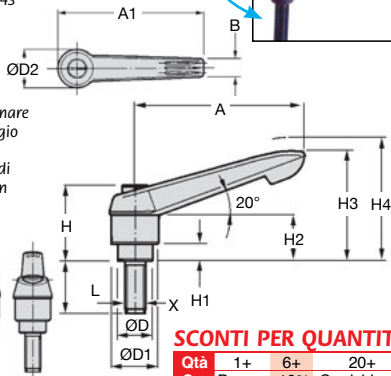

Utilizzo

- Per la ripresa durante il serraggio, sollevare l'impugnatura per disimpegnare la dentatura dell'elemento di serraggio e rimetterla nella posizione iniziale. Rilasciando l'impugnatura la molla di richiamo rimette automaticamente in presa la dentatura.

Opzioni

- Altre lunghezze di asta a L (a partire da 10 pezzi)

Info.

- H4: leva disinserita

SCONTI PER QUANTITÀ

Qtà	1+	6+	20+
Sc.	Prezzo -10%	Su richiesta	

Codice		Asta filettata X		L		ØD	ØD1	ØD2
Acciaio	Inox	H1	H1	Acciaio	Inox			
CLB01T5	CLB01T5SS	M5	4,0	50	25	10,0	13,0	14,5
CLB01T6	CLB01T6SS	M6	4,0	50	50	10,0	13,0	14,5
CLB02T8	CLB02T8SS	M8	6,5	60	60	13,5	18,0	19,5
CLB02T10	CLB02T10SS	M10	6,5	60	60	13,5	18,0	19,5
CLB03T10	CLB03T10SS	M10	10,0	60	60	16,0	21,5	23,0
CLB04T10	-	M10	10,0	90	-	19,0	25,5	27,5
CLB04T12	CLB04T12SS	M12	10,0	90	60	19,0	25,5	27,5
CLB05T12	-	M12	12,0	90	-	23,0	30,0	32,5
CLB05T16	CLB05T16SS	M16	12,0	90	60	23,0	30,0	32,5

Codice		H				A			N. di denti	Stock		Prezzo unit. 1 a 5	
Acciaio	Inox	H	H2	H3	H4	A	A1	B		Acciaio	Inox	Acciaio	Inox
CLB01T5	CLB01T5SS	24,5	15,0	30,0	33,5	40	47,0	7,5	16	✓	✓	13,38 €	17,19 €
CLB01T6	CLB01T6SS	24,5	15,0	30,0	33,5	40	47,0	7,5	16	✓	✓	13,38 €	18,48 €
CLB02T8	CLB02T8SS	28,5	17,5	41,5	45,5	65	75,0	9,5	20	✓	✓	16,56 €	22,92 €
CLB02T10	CLB02T10SS	28,5	17,5	41,5	45,5	65	75,0	9,5	20	✓	✓	16,56 €	22,85 €
CLB03T10	CLB03T10SS	37,0	24,0	53,5	58,0	80	91,5	11,0	22	✓	✓	18,32 €	26,10 €
CLB04T10	-	43,0	26,0	61,0	66,0	95	109,0	13,0	24	✓	-	21,89 €	-
CLB04T12	CLB04T12SS	43,0	26,0	61,0	66,0	95	109,0	13,0	24	✓	✓	21,89 €	33,58 €
CLB05T12	-	49,0	33,0	72,0	77,0	110	126,0	15,5	26	✓	-	27,56 €	-
CLB05T16	CLB05T16SS	49,0	33,0	72,0	77,0	110	126,0	15,5	26	✓	-	27,56 €	42,83 €

*Nei limiti delle disponibilità - Dimensioni in mm

Altri prodotti...



BAC105

Contenitore a becco,
8mm



BABtss

Perno autobloccante
inox 303, Inox 303



MHMEP

Manovella ad
impugnatura girevole,
Prealesata



HD

Giunto cardanico
doppio ad aghi,
Sollecitazioni intense



DOMI120

Accessori di
collegamento, Piastra



NAST

Rotelle. Con anello
interno



VQTplq

Chiusura ¼ di giro -
Piastra di bloccaggio,
Montaggio con
controllo...

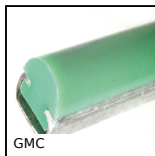

GMC

Guida prodotto
laterale tonda, Per
imbottigliamento e
imballaggio



DOMI30

Slitta di regolazione
Domino 30, Slitta
DOMILINE 30 con



PR125

Piede fissabile con
snodo - poliammide, Ø
123



AT5courroie

Cinghia chiusa
posizionamento AT,
AT5 Poliuretano



CHMR63

Riduttore a ruota e
vite senza fine, fino a
196 Nm

Prodotti correlati



PCLA_T

Maniglia a ripresa -
maschio, Plastica



CLASS

Maniglia a ripresa -
maschio, Inox



PCLA_T

Maniglia a ripresa,
Plastica



PCLA_M

Maniglia a ripresa -
femmina, Plastica