

# Maniglia a ripresa



CLBM  
CLBMSS

Zamak

## - Maniglia a ripresa con inserto maschiato

### - Materiali:

Inserto: acciaio classe 5.8 o inox 303

Manopola: zamak a norma DIN 1743 ØD2

### - Finitura: acciaio brunito

- Colore: nera, con rivestimento in resina sintetica

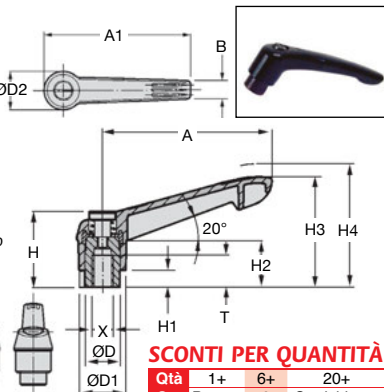

## Utilizzo

- Per la ripresa durante il serraggio, sollevare l'impugnatura per disimpegnare la dentatura dell'elemento di serraggio e rimetterla nella posizione iniziale. Rilasciando l'impugnatura la molla di richiamo rimette automaticamente in presa la dentatura.

## Info.

- H4: leva disinserita

## SCONTI PER QUANTITÀ

Qtà	1+	6+	20+
Sc.	Prezzo	-10%	Su richiesta

Codice	Maschiatura							
	X	T	ØD	ØD1	ØD2	H	H1	H2
CLB01M4	M4	9	10,0	13,0	14,5	24,5	4,0	15,0
CLB01M5	M5	9	10,0	13,0	14,5	24,5	4,0	15,0
CLB01M6	M6	9	10,0	13,0	14,5	24,5	4,0	15,0
CLB02M6	M6	12	13,5	18,0	19,5	28,5	6,5	17,5
CLB02M8	M8	12	13,5	18,0	19,5	28,5	6,5	17,5
CLB03M8	M8	14	16,0	21,5	23,0	37,0	10,0	24,0
CLB03M10	M10	14	16,0	21,5	23,0	37,0	10,0	24,0
CLB04M10	M10	17	19,0	25,5	27,5	43,0	10,0	26,0
CLB04M12	M12	17	19,0	25,5	27,5	43,0	10,0	26,0
CLB05M12	M12	23	23,0	30,0	32,5	49,0	12,0	33,0
CLB05M16	M16	23	23,0	30,0	32,5	49,0	12,0	33,0

Codice	Inox		H3	H4	A	A1	B	N. di denti	Stock*		Prezzo unit. 1 a 5	
	Acciaio	Inox							Acciaio	Inox	Acciaio	Inox
CLB01M4	-	-	30,0	33,5	40	47,0	7,5	16	✓	-	11,56 €	-
CLB01M5	CLB01M5SS	-	30,0	33,5	40	47,0	7,5	16	✓	-	11,56 €	16,22 €
CLB01M6	CLB01M6SS	-	30,0	33,5	40	47,0	7,5	16	✓	-	11,56 €	16,22 €
CLB02M6	CLB02M6SS	-	41,5	45,5	65	75,0	9,5	20	✓	✓	14,62 €	20,12 €
CLB02M8	CLB02M8SS	-	41,5	45,5	65	75,0	9,5	20	✓	-	14,62 €	20,12 €
CLB03M8	CLB03M8SS	-	53,5	58,0	80	91,5	11,0	22	✓	-	15,97 €	22,85 €
CLB03M10	CLB03M10SS	-	53,5	58,0	80	91,5	11,0	22	✓	-	15,97 €	22,85 €
CLB04M10	CLB04M10SS	-	61,0	66,0	95	109,0	13,0	24	✓	-	18,07 €	29,72 €
CLB04M12	CLB04M12SS	-	61,0	66,0	95	109,0	13,0	24	✓	-	18,07 €	29,72 €
CLB05M12	CLB05M12SS	-	72,0	77,0	110	126,0	15,5	26	✓	-	22,44 €	36,17 €
CLB05M16	CLB05M16SS	-	72,0	77,0	110	126,0	15,5	26	✓	-	22,44 €	36,25 €

\*Nei limiti delle disponibilità - Dimensioni in mm

## Altri prodotti...



HTD8M\_50

Puleggia dentata di trasmissione tipo HTD, HTD8 Ghisa



BABT

Perno autobloccante, Inox temprato



CSS

Snodo sferico, acciaio/acciaio autolubrificante



PCS8ECO

Pignone a catena - acciaio, 8mm (DIN 05B-1)



DOMI120

Accessori di collegamento, Kit di fissaggio



BAG-MI

Anello di serraggio con intaglio e maniglia a leva, Acciaio



MDB\_MTB

Ingranaggio conico in plastica stampata, 3:1



BSM\_LOK

Pressore a molla con esagono incassato, LONG-LOK - corpo in acciaio,...

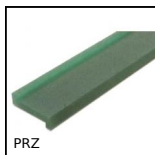

PRZ

Profilo supporto per catena, Profilo a Z da



DER80

Motore inox AC asincrono da 0,55 a



RDCss

Tenditore, Inox

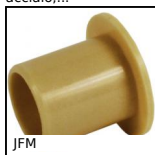

JFM

Cuscinetto a collare, Polimero universale

## Prodotti correlati



PCLA\_M

Maniglia a ripresa - femmina, Plastica



CLASS

Maniglia a ripresa - femmina, Inox



CLB\_T

Maniglia a ripresa, Zamak



CLASS

Maniglia a ripresa - maschio, Inox