

Inx Aci Piastrina di riscontro piatta per chiusura

Modello larghezza 22 mm

AC144

- Chiusura tramite aggancio

- Materiali :

Acciaio zincato bianco

Inox 18/8 grezzo

Accessori

- Chiusure GP75-ZB e GP75-SS

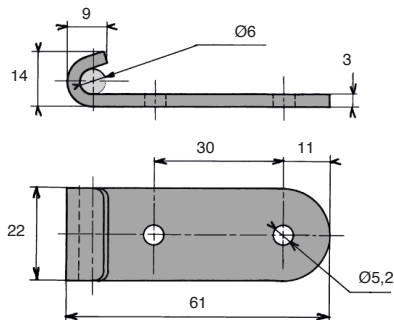

SCONTI PER QUANTITÀ

| Qtà | 1+ | 51+ | 101+ | 250+ | 400+ |
|------------|------|------|------|--------------|------|
| Sc. Prezzo | -10% | -15% | -20% | Su richiesta | |

| Codici | Materiali | Ideale per chiusura a leva | Massa (g) | Stock* | Prezzo unit. 1 a 50 |
|---------------------------|-----------|----------------------------|-----------|--------|---------------------|
| Montaggio in linea | | | | | |
| AC144-ZB | Acciaio | GP75-ZB | 35 | - | 0,86 € |
| AC144-SS | Inox | GP75-SS | 35 | ✓ | 2,74 € |

Dimensioni in mm

Altri prodotti...



CHAL3

Cerniera piana,
Alluminio



BLH60

Rinvio angolare a L,
da 19 a 70 Nm



PRF4590

Profilato alluminio
standard, 45 x 90 mm



GLB

Volantino a 6 lobi,
Tecno-polimero -
Ottone



UCF PBT

Cuscinetto a flangia
quadrata polimero
inox, Polimero e inox



F7-SN

Visualizzatore
multifunzione,
Supporto snodato



PRF_BR

Elementi di giunzione,
Flangia per profilato



VT

Limitatore di coppia
ad attrito Vari-Tork®,
0.53 a 1.32 Nm



SH1

Ingranaggio elicoidale
ad assi paralleli,
Plastica lavorata



BOX-TOR-G

Valigetta di
guarnizioni toriche in
nitrile, 3.00 x 1.50mm

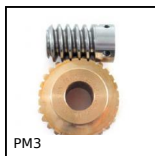

PM3

Coppia ruota e vite
senza fine, Bronzo



SCR

Accessori per ventosa,
Inserto per ventosa -
Vite cava

Prodotti correlati



GP75

Chiusura a leva molla
a trazione
compensata,
Standard (GP75)