

Folding lifting ring, for welding

Dual anchorage

RUD® VRBS

- 2 mounting points for a better distribution of applied forces
- High dynamic and static strength
- Low profile
- SWL clearly marked
- Mounts manufactured from S355J2+N steel alloy
- Corrosion resistant epoxy coating

Info.

- Ring should not be welded
- Welding to be carried out by suitably qualified personnel
- Ring profile conforms to the welding requirements of DIN18800 (welding instructions supplied with the product)
- Position of welding positions (closed, HV) ensures corrosion resistance and renders the ring suitable for use outside.

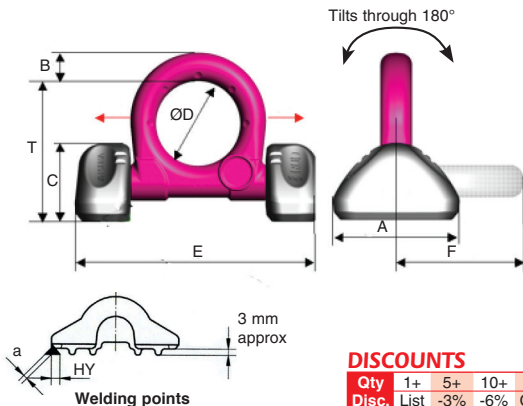

DISCOUNTS

Qty	1+	5+	10+	15+
Disc.	List	-3%	-6%	On request

Part number	SWL (t)	A	B	C	ØD	E	F	T	Weight (kg)	Taille soudure	Price each 1 to 4
VRBS-4	4,0	62	14	28	48	135	71	65	0,8	HY 4 + a 3	46,36 €
VRBS-6	6,7	88	20	39	60	170	92	84	1,6	HY 5,5 + a 3	81,47 €
VRBS-10	10,0	100	22	46	65	195	100	95	2,6	HY 6 + a 4	136,59 €
VRBS-16	16,0	130	30	57	90	263	134	127	5,53	HY 8,5 + a 3	245,85 €
VRBS-31	31,5	160	42	79	130	375	195	178	15,6	HY 18 + a 4	596,45 €

Dimensions in mm