

Toggle clamps

Rapid clamping - reliable fastening

Durable and reliable: More reliable, more user-friendly and safer. These clamps are quick to use, reliable and accurate. The use of high quality materials ensures a long working life.

Advantages

- **Extremely tough** : All models will withstand 300,000 clamping cycles without problems
- **Durable** : High-quality bushes - no scratching
- **Extremely robust** : tCorrosion-resistant NITROX coating
- **Easy to use** : The fixed headed nut facilitates spindle adjustment
- **Reliable** : Constant level of force during both opening and closing
- **Ideal where space is restricted** : The slim design allows sufficient space for safe operation
- **Robust by design** : Thanks to use of U-shaped conical clamping arm
- **Safe to use** : No sharp edges prevent risk of anything getting trapped
- **Quick to put into operation** : Can be easily modified thanks to a wide range of accessories
- **Ergonomic design** : Easy to operate whilst wearing work gloves
- **Reflection free finish** : Suitable for use around lasers
- **Risk free use** : With increased space between clamping arm and handle avoids risks of squashing
- **Extremely adaptable** : Rectangular mounting holes allows installation on existing fixing points
- **Efficient clamping and locking** : The integrated design avoids any risks of squashing. Easy to use even whilst wearing gloves.

Locking mechanism – principal of operation



1. Locked in closed position. Redesigned handle ensures safe operation as the smooth contours avoid any risk of anything being trapped.

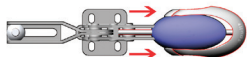

2. Inner locking mechanism with automatic safety catch. The lock is released by pulling the handle.



3. Locked in open position. Releasing the handle engages the locking mechanism.



Vertical toggle clamp

New

SLVHLOK

With locking mechanism

High quality swivel bush with vertical foot and adjustable spindle

Constant level of force during both opening and closing

Increased stability thanks to U-shaped clamping arm
Fitted with automatic locking mechanism

- Material :

Nitro carburised steel with blackened finish

Polyamide handle

Locking mechanism TPE

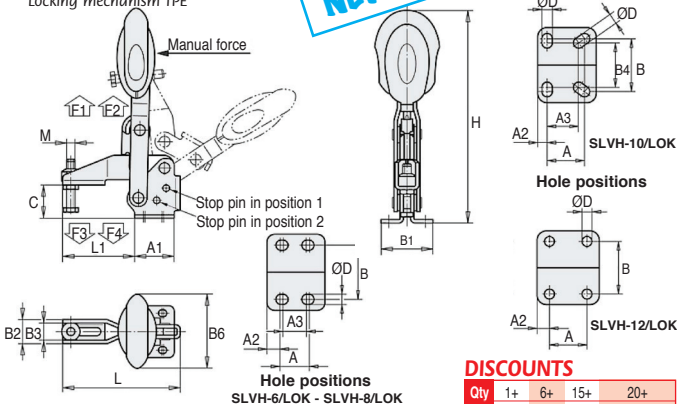

DISCOUNTS

Qty	1+	6+	15+	20+
Disc.	List	-5%	-10%	On request

Part number	Opening angle (holding arm)			Opening angle (Handle)			Manual force N	Holding force		Clamping force	
	Pos. 1	Pos. 2	Stop pin removed	Pos. 1	Pos. 2	Stop pin removed		F1 (N)	F2 (N)	F3 (N)	F4 (N)
SLVH-6/LOK	56°	83°	156°	46°	56°	84°	160	1350	1650	920	1050
SLVH-8/LOK	13°	93°	157°	26°	61°	86°	190	2000	2800	940	1350
SLVH-10/LOK	6°	97°	175°	19°	59°	91°	250	2500	4500	1500	2800
SLVH-12/LOK	11°	88°	163°	24°	60°	91°	280	3000	5500	1400	2800

Part number	M	A	A1	A2	A3	B	B1	B2	B3	B4	B6	C	ØD	H	L	L1	Price
																	each 1 to 5
SLVH-6/LOK	M6x35	14	29	7	12	27	38	17,5	12,4	-	53,4	24,7	5,5	162,9	86,5	53	49,82 €
SLVH-8/LOK	M8x45	21	39	9	19	32	45	20,6	15,5	-	51,1	32,7	6,8	191,4	107	62	51,99 €
SLVH-10/LOK	M10x55	32	50	8	27	45	64	25,5	18,4	38	56,5	38,7	9	230,5	153	95	71,20 €
SLVH-12/LOK	M12x70	32	53	10,5	-	45	63	28	20,9	-	56,5	46,7	8,8	249,1	173,5	113,5	73,59 €