

Self-centering locking assembly



RT61

Torque **medium/low**

- Inserts between the shaft and the bore
- Contact pressure spread evenly
- Easy to assembly and dismantle
- Reduced width
- Backlash free
- **No constraints due to keyway**
- Increases the resistant part of the shaft
- Suitable for alternating rotational movement
- Material
Steel C45E



Info.

- **PN: hub surface pressure
- **Pw: shaft surface pressure

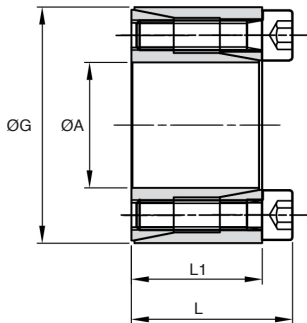

DISCOUNT

Qty	1+	6+	20+	40+	60+	100+
Disc.	List	-10%	-15%	-20%	-25%	On request

Part number	ØA	ØG	L	L1	Screw M	Tightening torque TA (Nm)	Transmissible torque T (Nm)	Pw** (N/mm ²)	PN* (N/mm ²)	Price each 1 à 5
RT61-10-20	10	20	15,5	13	4xM2,5x12	1,2	19	89	45	- 9,38 €
RT61-12-22	12	22	15,5	13	4xM2,5x12	1,2	23	75	41	- 9,38 €
RT61-14-26	14	26	20,0	17	4xM3x16	2,1	39	71	38	- 9,92 €
RT61-15-28	15	28	20,0	17	4xM3x16	2,1	42	66	35	- 9,92 €
RT61-16-32	16	32	21,0	17	4xM4x16	4,9	77	107	54	- 10,62 €
RT61-18-35	18	35	25,0	21	4xM4x20	4,9	87	77	40	- 11,49 €
RT61-19-35	19	35	25,0	21	4xM4x20	4,9	91	73	40	- 11,49 €
RT61-20-38	20	38	26,0	21	4xM5x20	10,0	157	113	60	- 12,32 €
RT61-22-40	22	40	26,0	21	4xM5x20	10,0	173	103	57	- 13,54 €
RT61-24-47	24	47	32,0	26	4xM6x24	17,0	268	110	56	- 16,99 €
RT61-25-47	25	47	32,0	26	4xM6x24	17,0	279	105	56	- 17,25 €

*Depending on availability - Dimensions in mm

RT61ss

Torque **medium/low**

- Inserts between the shaft and the bore
- Contact pressure spread evenly
- Easy to assembly and dismantle
- Reduced width
- Backlash free
- **No constraints due to keyway**
- Increases the resistant part of the shaft
- Suitable for alternating rotational movement
- Material
Stainless steel

stainless steel



Info.

- **Pn: hub surface pressure
- **Pw: shaft surface pressure

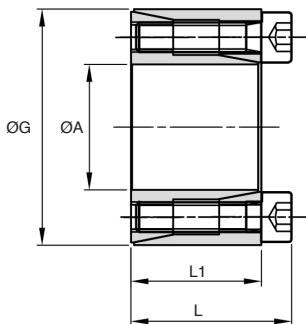

DISCOUNT

Qty	1+	2+	5+
Disc. List	-5%	On request	

Part number	ØA	ØG	L	L1	Screw M	Tightening torque TA (Nm)	Transmissible torque T (Nm)	Pw** (N/mm ²)	Pn* (N/mm ²)	Stock*	Price each
RT61-10-20/SS	10	20	15,5	13	4xM2,5x12	0,5	6	33	17	-	21,88 €
RT61-12-22/SS	12	22	15,5	13	4xM2,5x12	0,5	7	26	15	-	22,15 €
RT61-14-26/SS	14	26	20,0	17	4xM3x16	0,9	13	28	15	-	23,70 €
RT61-15-28/SS	15	28	20,0	17	4xM3x16	0,9	14	26	14	-	24,15 €
RT61-16-32/SS	16	32	21,0	17	4xM4x16	2,2	28	45	23	-	25,53 €
RT61-18-35/SS	18	35	25,0	21	4xM4x20	2,2	32	32	17	-	27,73 €
RT61-19-35/SS	19	35	25,0	21	4xM4x20	2,2	34	31	17	-	27,80 €
RT61-20-38/SS	20	38	26,0	21	4xM5x20	4,2	55	45	24	-	29,85 €
RT61-22-40/SS	22	40	26,0	21	4xM5x20	4,2	61	41	23	-	33,50 €
RT61-24-47/SS	24	47	32,0	26	4xM6x24	7,3	96	44	23	-	39,03 €
RT61-25-47/SS	25	47	32,0	26	4xM6x24	7,3	100	43	23	-	42,08 €

*Depending on availability - Dimensions in mm