

# Fixed anti-vibration foot mount New

## PAV

For loads up to 35,000 N

- Adjustable anti-vibration floor mount
- Fine thread for an accurate level
- Materials:
  - Body: Chromed sheet steel
  - Thread: Chromed steel
  - Base: Rubber NBR 80 shore

### Applications

- Machine tools, presses, injection machines, compressors.

### Info

- Supplied with 1 nut and 1 washer

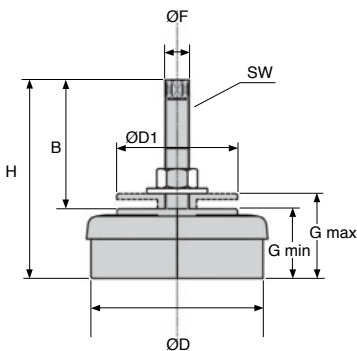

### DISCOUNTS

Qty	1+	6+	10+	15+
Disc.	List	-5%	-10%	On request

Part number	ØD	ØF	B	ØD1	SW	G	H	Max load		Price each 1 to 5
								Dynamic (N)	Static (N)	
PAV80-M12C	80	M12x1,25	87	60	8	40-50	136	2500	5000	35,18 €
PAV120-M16C	120	M16x1,5	93	80	9	45-58	150	4000	10000	59,31 €
PAV160-M20C	160	M20x1,5	125	100	12	53-65	190	9000	20000	98,01 €
PAV200-M20C	200	M20x1,5	125	130	12	69-82	207	15000	35000	134,70 €

Dimensions in mm