

- **Hinge for hatch opening**
- Its integrated stop avoids the need to add an external stop or a safety bracket
- Materials :
316 stainless steel

Advantages

- Ideal for horizontal use. When it reaches its stop, the hatch is held open under its own weight

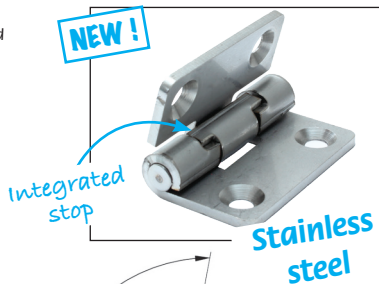

Typical application

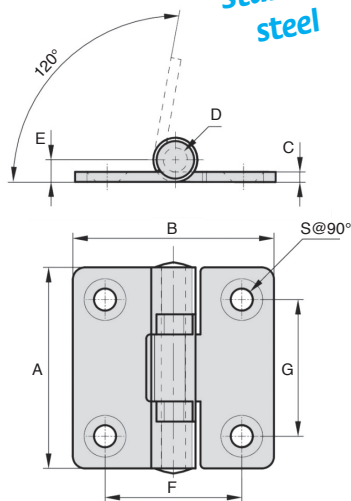
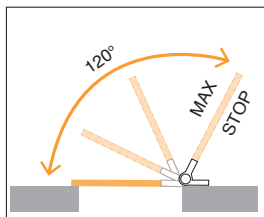

DISCOUNT

Qty	1+	6+	20+	50+
Disc. List	-10%	-20%	On request	

Part Number	A	B	C	D	E	F	G	S	Weight (g)	Stock*	Price each 1 à 5
CHAB50-50/SS	50	50	2,5	6	5,5	34	34	5,5	70	-	20,58 €

*Depending on availability - Dimensions in mm